



# 6BY3-160 Series

Configuration	4-stroke, water-cooled diesel engine		
Maximum output at crankshaft	117 kW@2800 rpm	[160 mhp@2800 rpm]	
Displacement	2.993 ltr	[183 cu in]	
Bore x stroke	84 mm x 90 mm	[3.31 in x 3.54 in]	
Cylinders	6 in line		
Combustion system	Direct injection with Bosch Common-rail system		
Aspiration	Turbocharger + charge-air cooler		
Low Idle rpm	650 - 950 rpm	[adjustable]	
Electric system	12V		
Alternator	12V / 150A option: secondary alternator 24V / 90A		
Start-assist	Glow-plug system		
Cooling system	Fresh water cooling by centrifugal fresh water pump		
	Sea water cooling by rubber impeller seawater pump		
Lubrication system	Enclosed, forced lubricating system		
Direction of rotation [crankshaft]	Counter clockwise viewed from flywheel side		
Dry weight without gear	328 kg	[723 lbs]	
Environmental	EU: RCD	BSO II	EMC
	US: EPA Tier3		
Engine mounting	Rubber type flexible mounting		

**NOTE:**

Fuel condition: Density at 15°C = 0.84 g/cm<sup>3</sup>

Fuel temperature 40°C at the inlet of the fuel injection pump [ISO 8665: 2006]

Technical data is according to ISO 8665: 2006/3046-1

**DIMENSIONS**

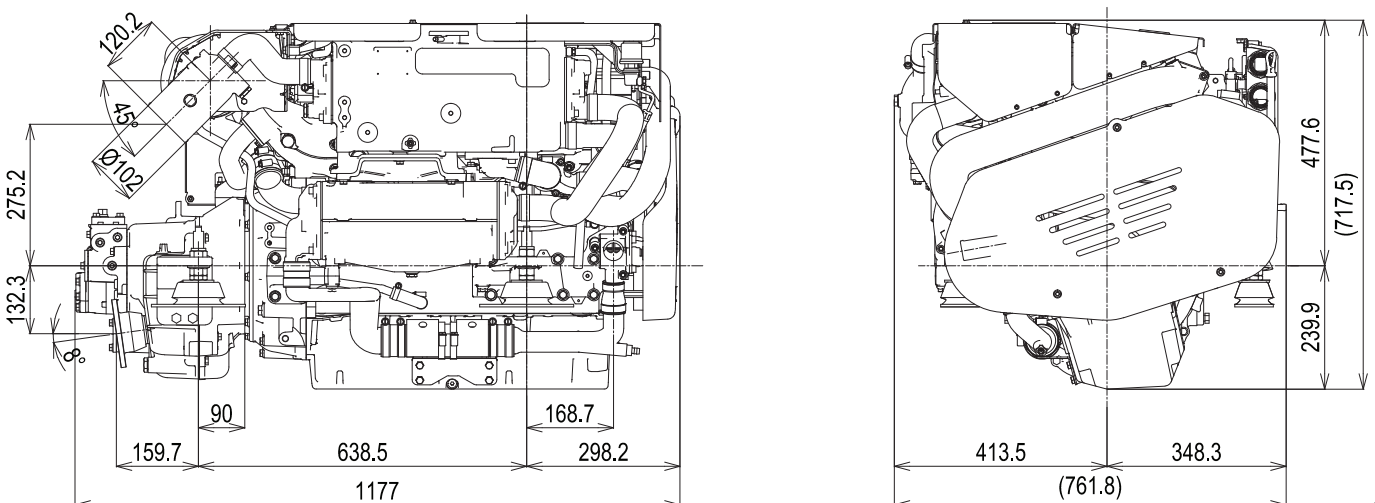

6BY3-160 with KMH51A Marine gear



PERFORMANCE CURVES

Power [kW]

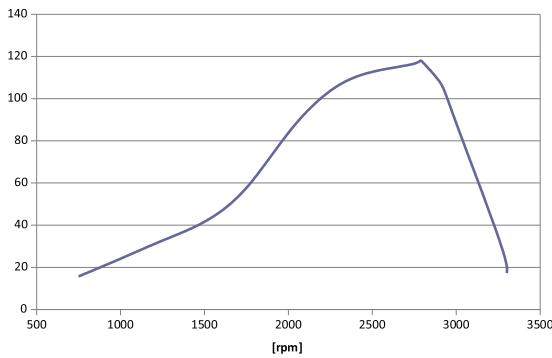

Torque [Nm]

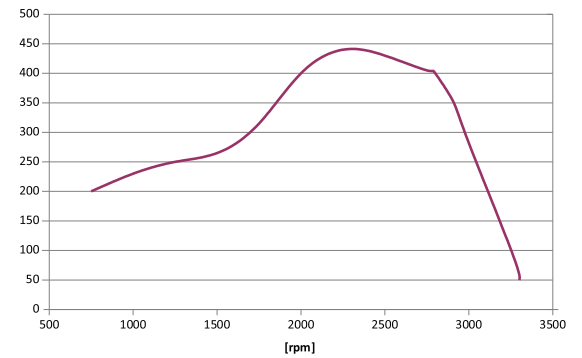

DRIVE SYSTEMS

Model	KMH50A [down angle 8°]		
Type	Hydraulic Actuated Multi-friction disc clutch		
Dry weight	43 kg excl. foot and cooler [=15.5 kg]		
Reduction ratio [fwd/asn]	1.67/1.67	2.13/2.13	2.43/2.43
Direction of rotation	Clockwise & Counterclockwise viewed from the stern		
Lub oil specifications	API class: CF or higher SAE grade #30		
Dry weight - engine & gear	375 kg		

Model	KMH50V [Integral V-drive 12°]		
Type	Hydraulic Actuated Multi-friction disc clutch		
Dry weight	59 kg excl. foot and cooler [=20 kg]		
Reduction ratio [fwd/asn]	1.22/1.22	1.58/1.58	2.08/2.08
Direction of rotation	Clockwise & Counterclockwise viewed from the stern		
Lub oil specifications	API class: CF or higher SAE grade #30		
Dry weight - engine & gear	395 kg		

CONTROL SYSTEM "LIMITED"

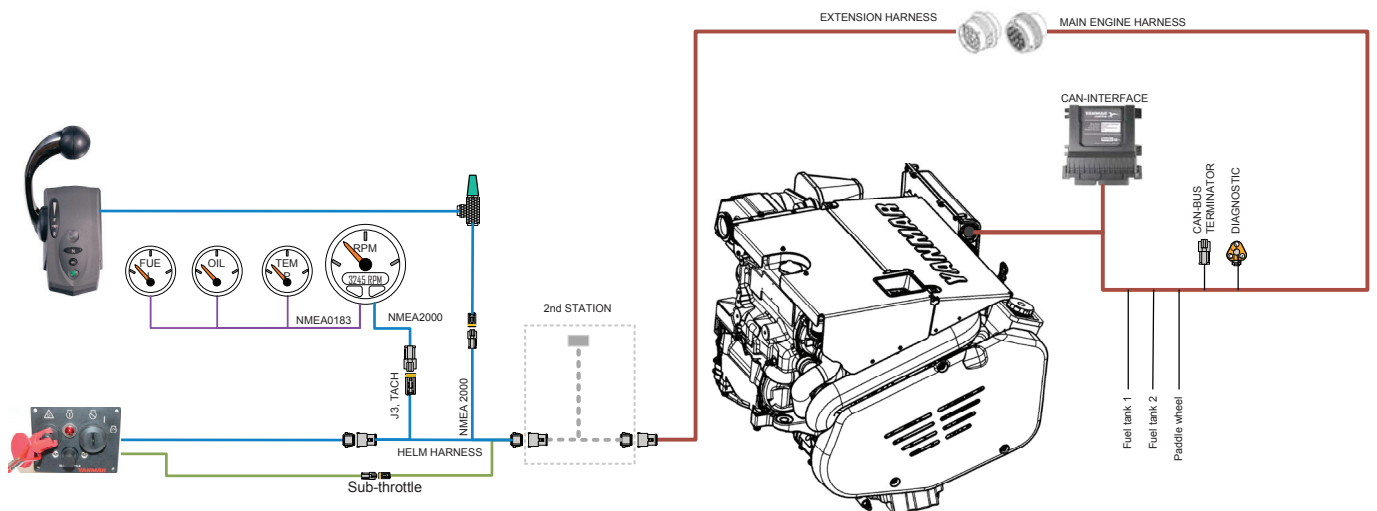

ENGINE ACCESORIES

**Standard engine package**

- Single pole, 150A Alternator
- Exhaust mixing elbow [L-type]
- Automatic glow-plug controller
- Flexible engine mounting
- Full NMEA2000 electronic control system [CAN-bus]

**Optional accesories**

- Secondary Alternator 24V / 90A
- High-riser mixing elbow [instead of L-elbow]
- Exhaust-side 2<sup>nd</sup> dipstick
- Electric gearshift
- Trolling on gearbox [mechanical and electrical]
- NMEA2000 digital display

NOTE: All data subject to change without notice. Text and illustrations are not binding.