



4JH110 Common Rail Series

Configuration	4-stroke, vertical, water-cooled diesel engine	
Maximum output at crankshaft	* 80.9 kW@3200 rpm	[110 mhp@3200 rpm]
Displacement	2.0 ltr	[122 cu in]
Bore x stroke	84 mm x 90 mm	[3.31 in x 3.54 in]
Cylinders	4 in line	
Combustion system	Direct injection with common rail system	
Aspiration	Turbocharged with intercooler	
Starting system	Electric starting 12V - 1.4 kW	
Alternator	12V - 125A	
Cooling system	Fresh water cooling by centrifugal water pump and rubber impeller sea water pump	
Lubrication system	Enclosed, forced lubricating system	
Direction of rotation [crankshaft]	Counterclockwise viewed from flywheel side	
Dry weight without gear	229 kg	[505 lbs]
Environmental	EU: RCD (will comply RCD2 from 2016) BSO II	EMC
	US: EPA Tier 3	
Engine mounting	Rubber type flexible mounting	

NOTE:

Fuel condition: Density at 15°C = 0.84 g/cm³: 1 kW = 1.3596 mhp = 1.3410 HP

* Fuel temperature 40°C at the inlet of the fuel injection pump [ISO 8665: 2006]

Technical data is according to ISO 8665: 2006

DIMENSIONS

Rear view

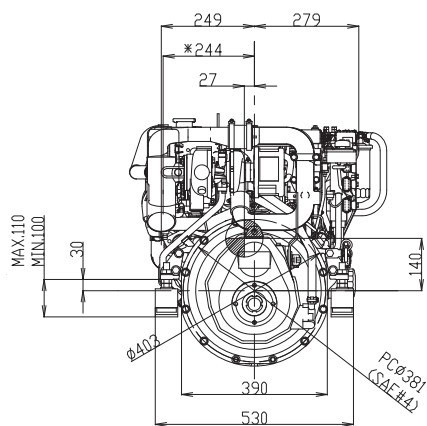

Right side view

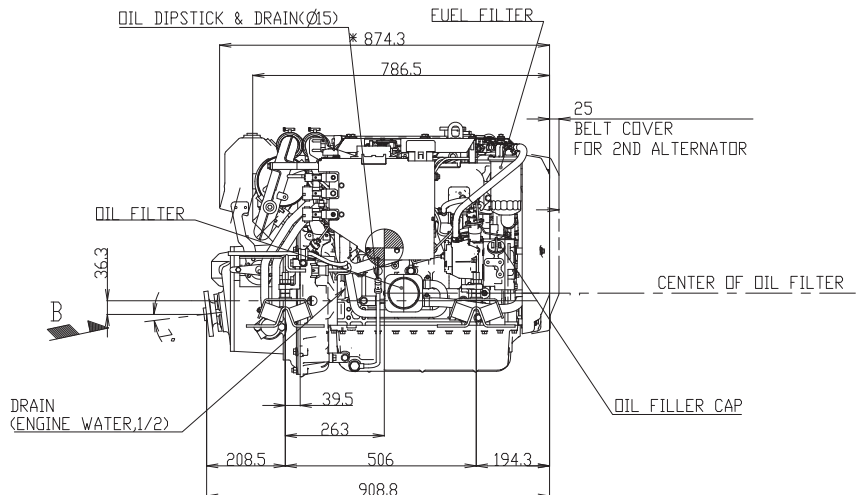

4JH110 with KM4A2 marine gear



PERFORMANCE CURVES

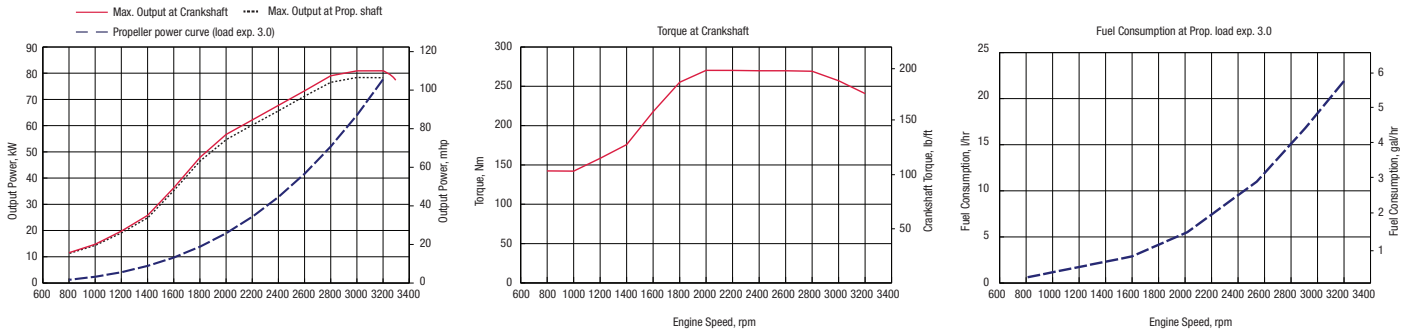

MARINE GEARS

Model	KMH4A [down angle: 8°]		ZF25A [down angle: 8°]		KM4A2 [down angle: 7°]			ZF30M	
Type	Hydraulic, multi disk clutch		Hydraulic, multi disk clutch		Mechanical cone clutch			Mechanical cone clutch	
Dry Weight	33 kg [73 lbs]		30 kg [66 lbs]		33 kg [73 lbs]			25 kg [55 lbs]	
Reduction Ratio [fwd/asn]	2.04/2.04	2.45/2.45	1.93/1.93	2.48/2.48	1.47/1.47	2.14 / 2.14	2.63/2.63	2.15/2.64	2.70/2.64
Propeller speed [fwd/asn]	1569/1569	1306/1306	1658/1658	1290/1290	2177/2175	1495/1494	1217/1216	1488/1212	1185/1212
Direction of rotation [propeller shaft - fwd]	Clockwise & counterclockwise viewed from stern		Clockwise & counterclockwise viewed from stern		Clockwise & counterclockwise viewed from stern			Clockwise viewed from stern	
Dry weight - engine & gear	261 kg [575 lbs]		259 kg [571 lbs]		263 kg [580 lbs]			254 kg [560 lbs]	
Length engine and gear/drive	907 mm [35.7 in]		905 mm [35.6 in]		909 mm [35.8 in]			925 mm [36.4 in]	

INSTRUMENT PANELS

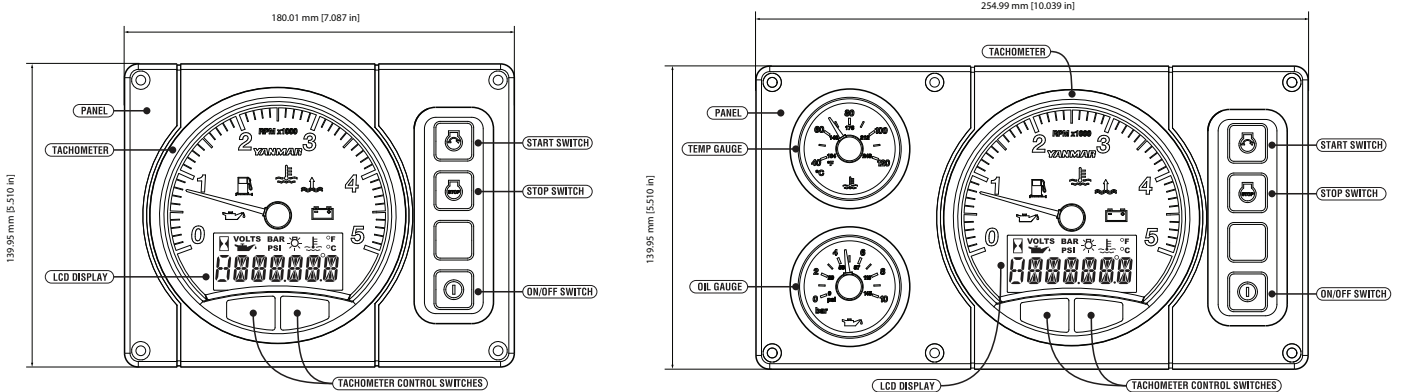

B25 STANDARD

C35 OPTIONAL

ACCESSORIES

Standard Package

- Set of flexible engine mounts
- Exhaust mixing elbow [L-type]
- V-belt safety cover
- Fresh water expansion tank
- Alternator 12V - 125A
- Operation manual
- B25-panel
- Sensors for instrument panel
- Engine Topcover for protection

Optional

- Second alternator 12V - 125A or 24V - 60A
- High-riser mixing elbow [instead of L-elbow]
- Extension wire harness [3m, 5m, 10m]
- Hot water kit with cocks
- Second station harness and panel
- C35-panel
- Oil pressure sensor for C35-panel
- NMEA 2000 convertor for Engine monitory system
- Emergency stop switch
- Seawaterpump front mounted

NOTE: All data subject to change without notice. Text and illustrations are not binding.