

DETAIL OF MOUNTING BLOCK

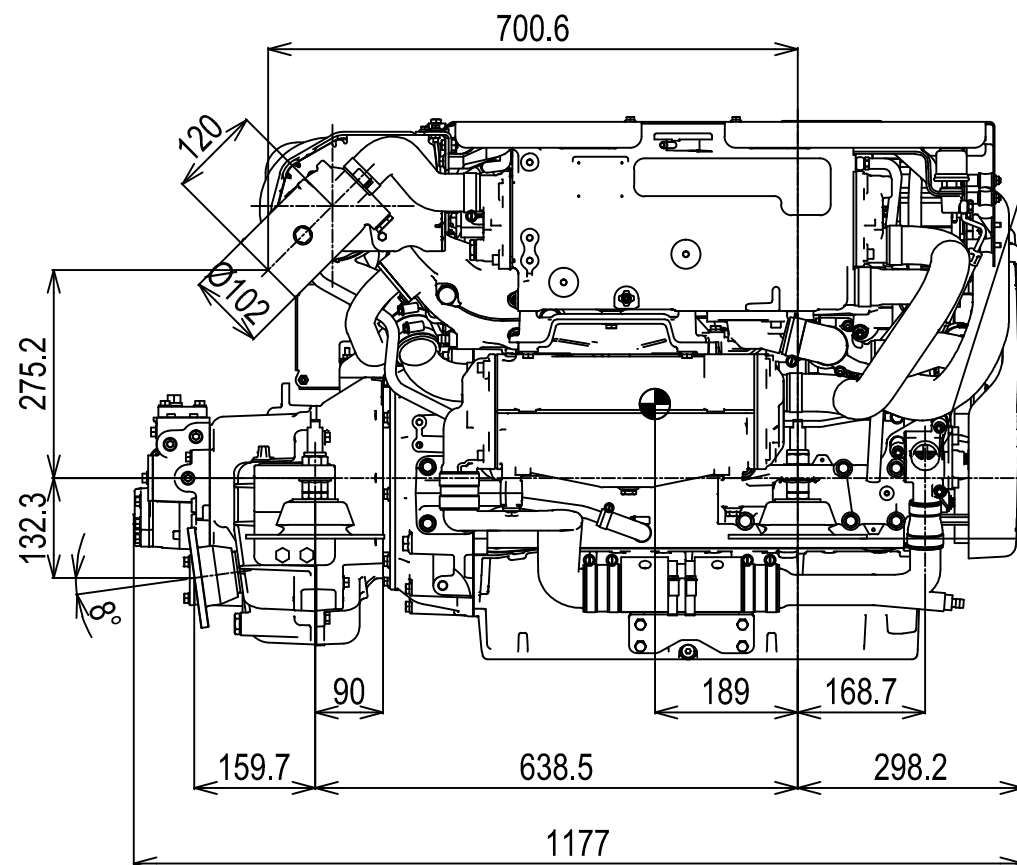

SEAWATER INLET
OUTSIDE Ø38

MIN. 80
MAX. 110

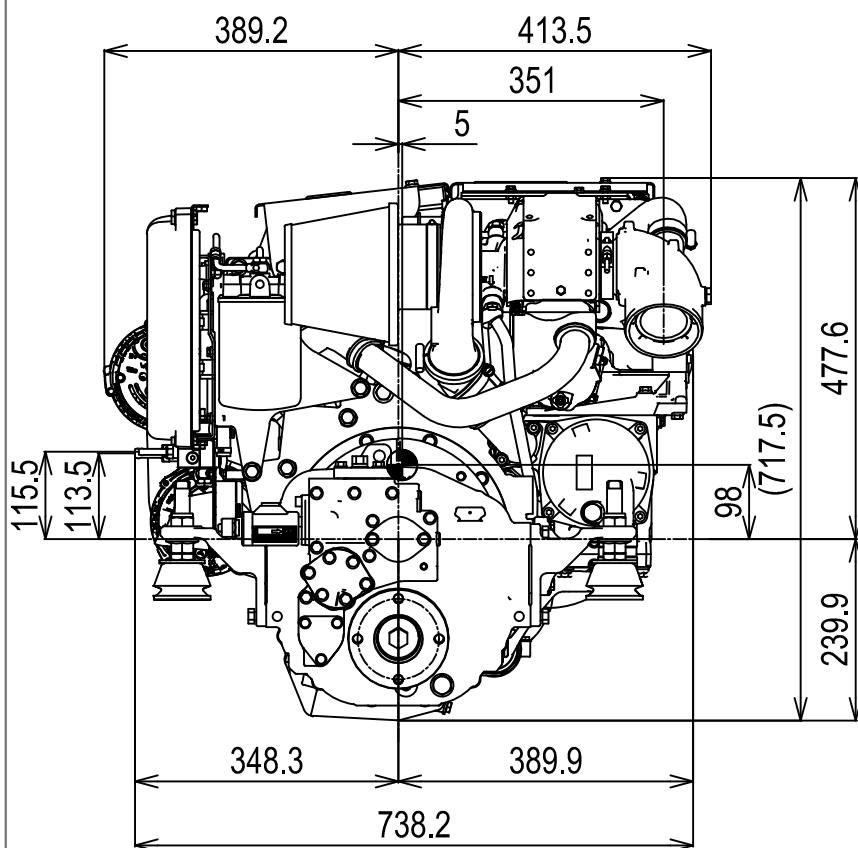
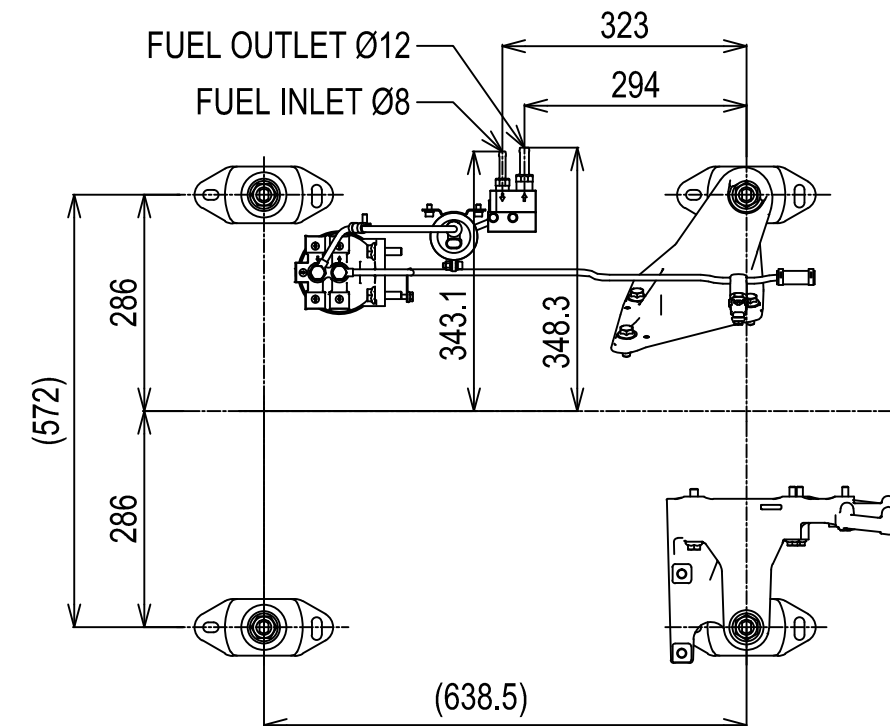
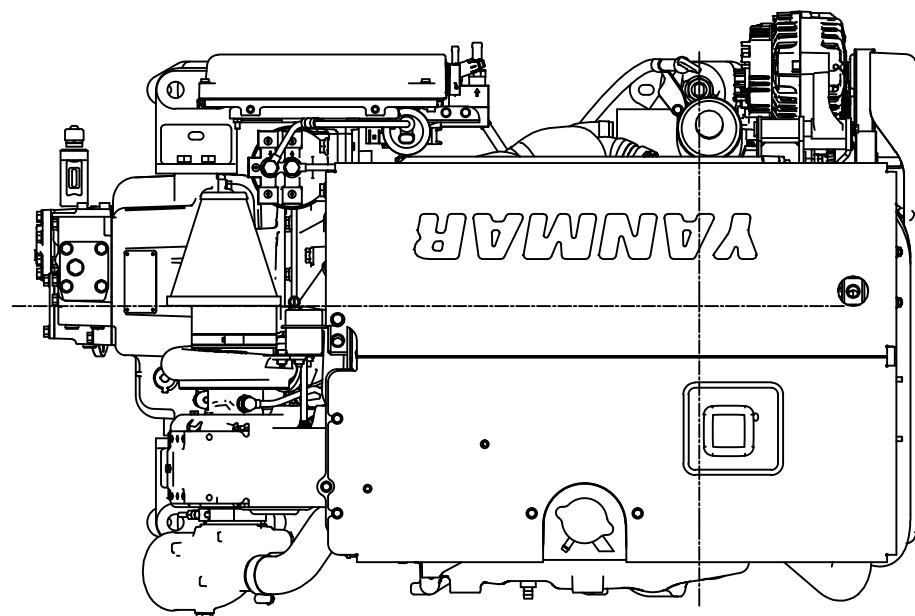
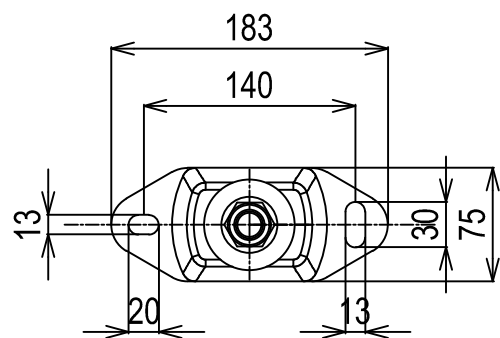
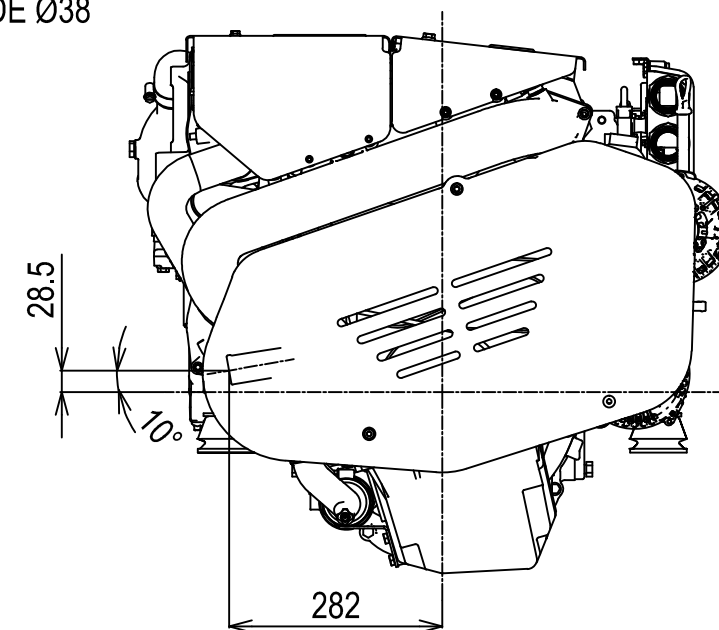

DETAIL OF COUPLING

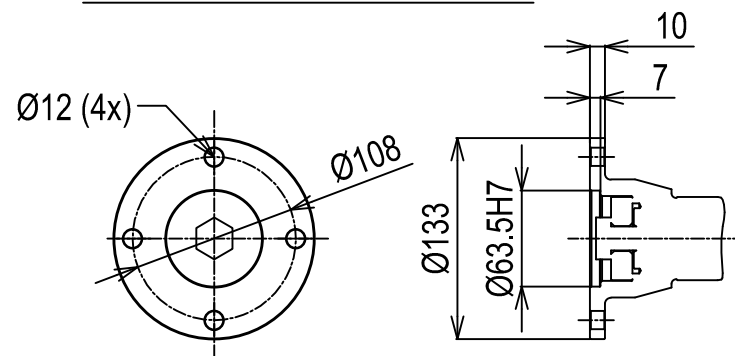

NOTE:

1. DWG. SHOWS MOUNTING BLOCKS AT ORIGINAL HEIGHT. ENGINE WEIGHT WILL COMPRESS BLOCKS BY 1MM (APPROX).
2. MOUNTING BLOCKS ARE EQUIPPED FOR STANDARD ACCESSORY.
3. ● SHOWS THE CENTER OF GRAVITY.
4. FOR ADDITIONAL INSTALLATION INFORMATION AND SPECIFICATIONS PLEASE REFER TO THE YANMAR ENGINE INSTALLATION MANUAL

Engine: 6BY3-160_KMH51A

Release: 29-08-2013

Scale: 1:10

Date: 12-09-2014

Dimensions: mm

YANMAR