

DIESELJET 445

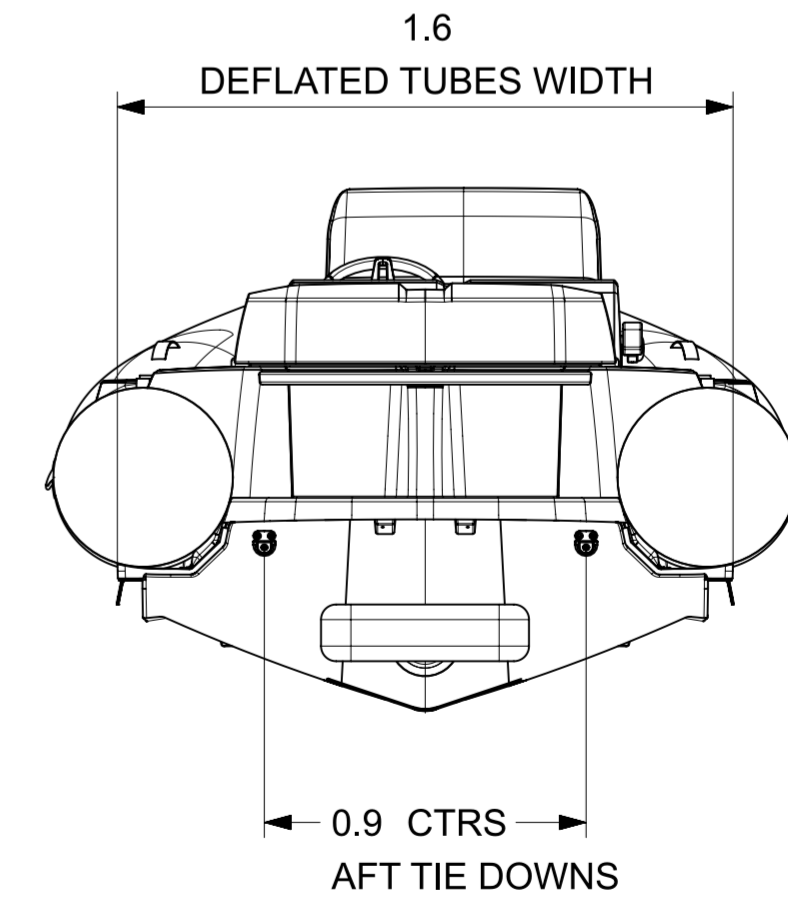
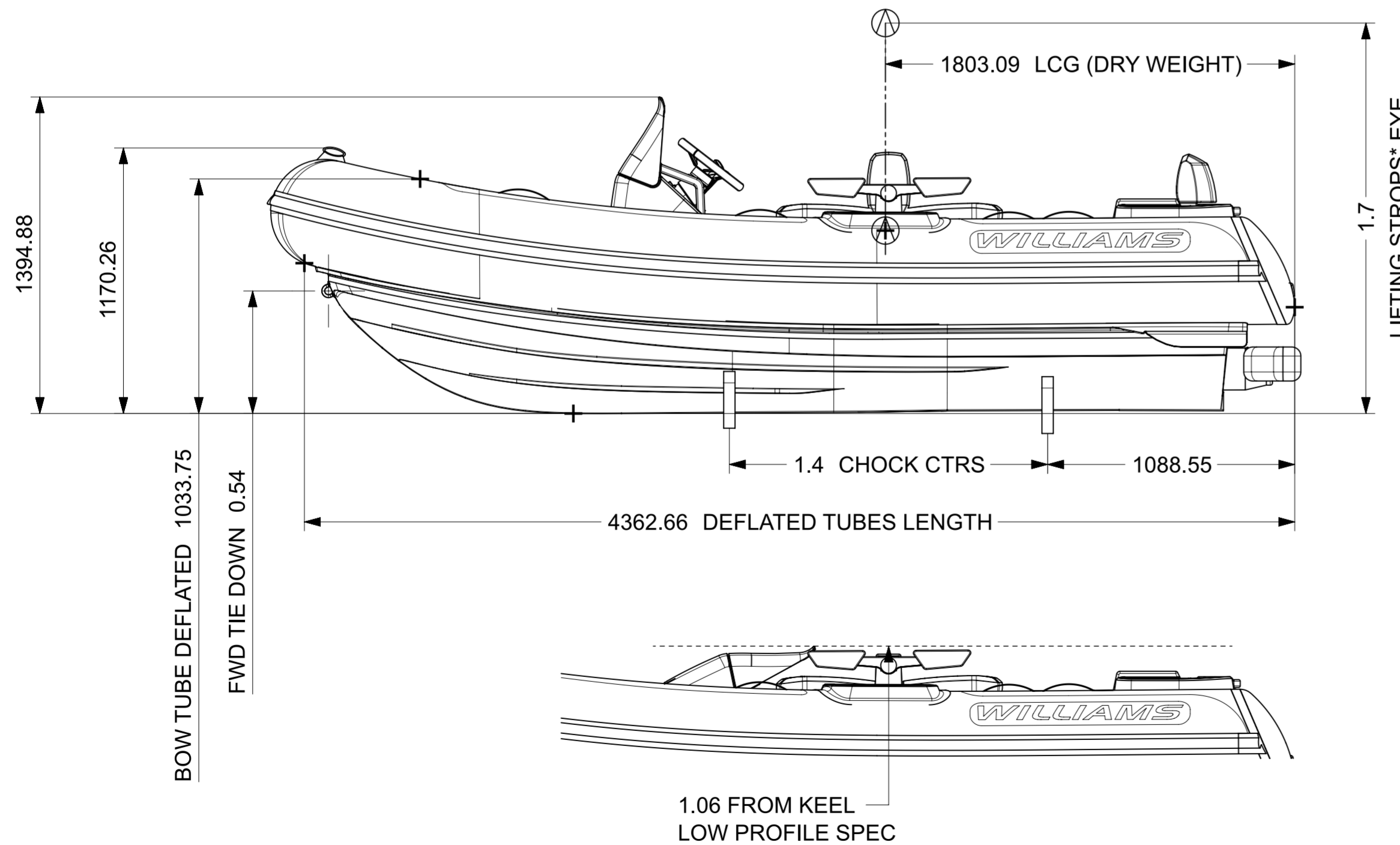
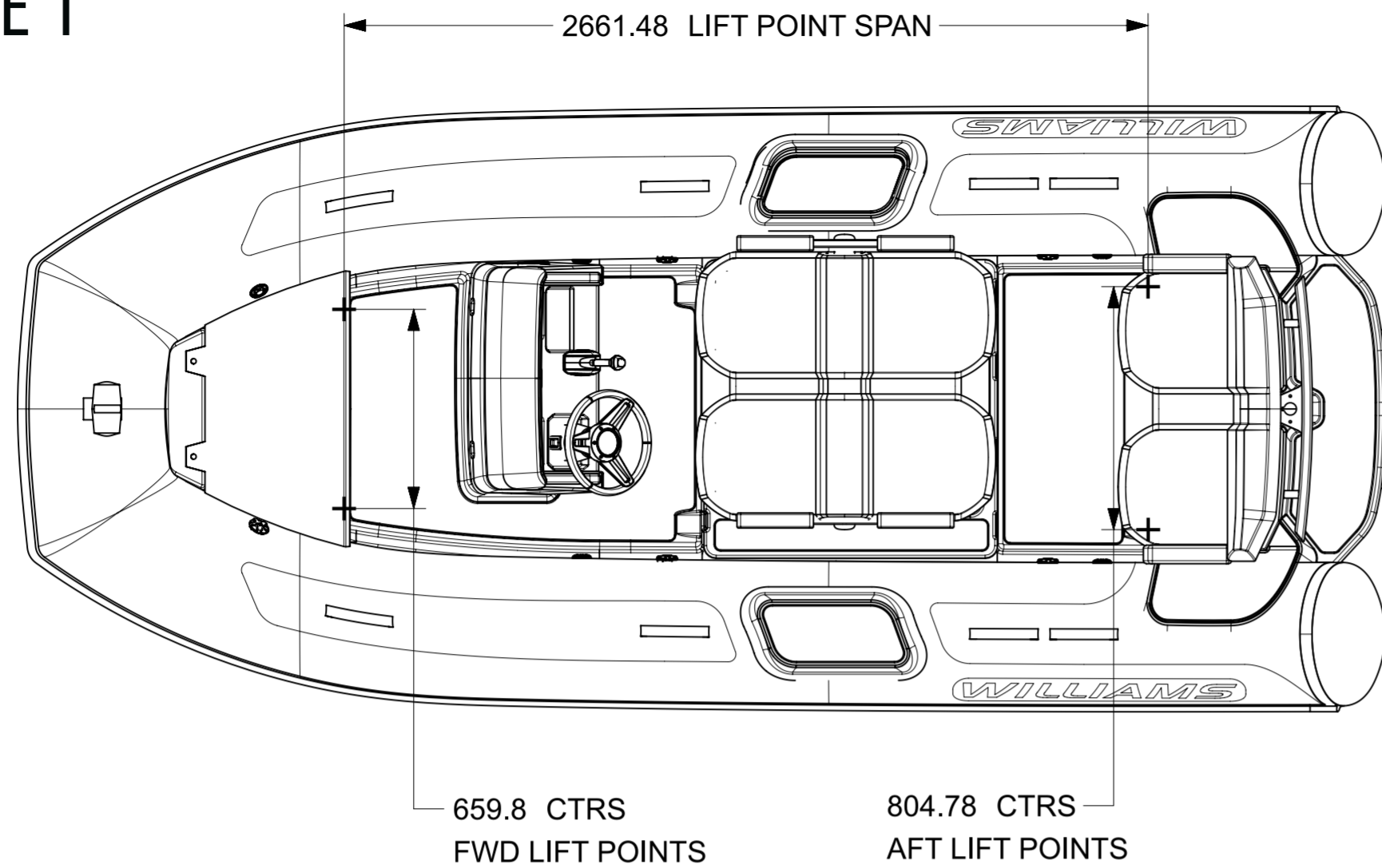

LENGTH	4.5 m (±1%)
BEAM	2.0 m (±1%)
DRAFT (FULLY LOADED)	0.47 m
ENGINE	YANMAR 4JH-110
POWER	110hp ≅ 81kW
DRY WEIGHT	885 Kg
SEATING CAPACITY	7 + 1
FUEL	DIESEL
FUEL CAPACITY	68L
MAX. SPEED	40 mph ≅ 64 kph
No. TUBE COMPARTMENTS	5
CE DESIGN CATEGORY	C

NOTES:

- LENGTH / BEAM TOLERANCE DUE TO VARIATION IN TUBE AIR PRESSURE.
- AVERAGE DRY WEIGHT STATED; ACTUAL WEIGHT DEPENDENT ON OPTIONS FITTED.
- GARAGE STORAGE OPTION:
 - HELM FOLDED DOWN.
 - QUICK RELEASE STEERING WHEEL.
 - BOW TUBE DEFLATED. (AUTO BOW TUBE INFLATOR OPTION REQUIRED*)
- LOW PROFILE OPTION:
 - LP ENGINE COVER
 - ROMOVABLE BACKREST & ARMRESTS
- REFER TO DRAWING RD1873 FOR CHOCK PROFILES.
- ALL DIMENSIONS IN METERS.

* OPTIONAL ACCESSORY

REV.	DATE	DETAILS	CW	VT
1	31/08/22	DOCUMENT PRODUCTION		

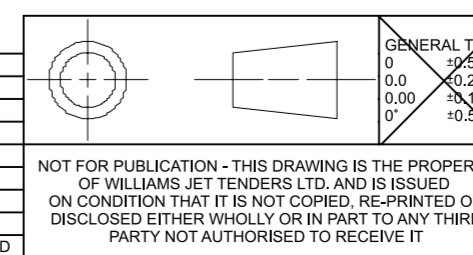

DRAWN	C.WYATT	31/08/22
APPVD	V.TAIDE	31/08/22
PROJECT:	P101 A	
INSPECTION LEVEL:	-	
MATERIAL & FINISH	-	
REMOVE ALL BURRS & BREAK SHARP EDGES	-	
GENERAL SURFACE FINISH Ra 1.6UM	-	
DIMENSIONS IN MM UNLESS STATED	-	
DO NOT SCALE DRAWING	-	

WILLIAMS

TITLE: DIESELJET 445 (2024MY)

PART NO. WPT-000445DJ-P101-2024MY-DATASHEET_dwg1

SCALE 1:20

SHEET 1 OF 1

A2