

# TURBOJET 285

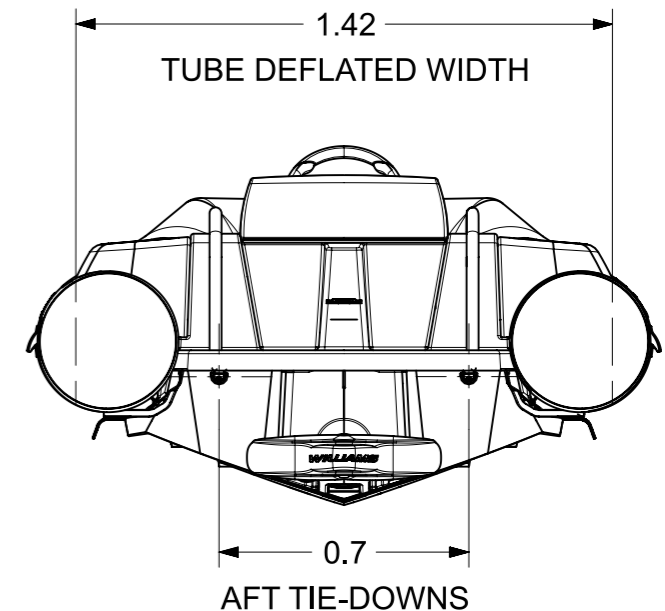
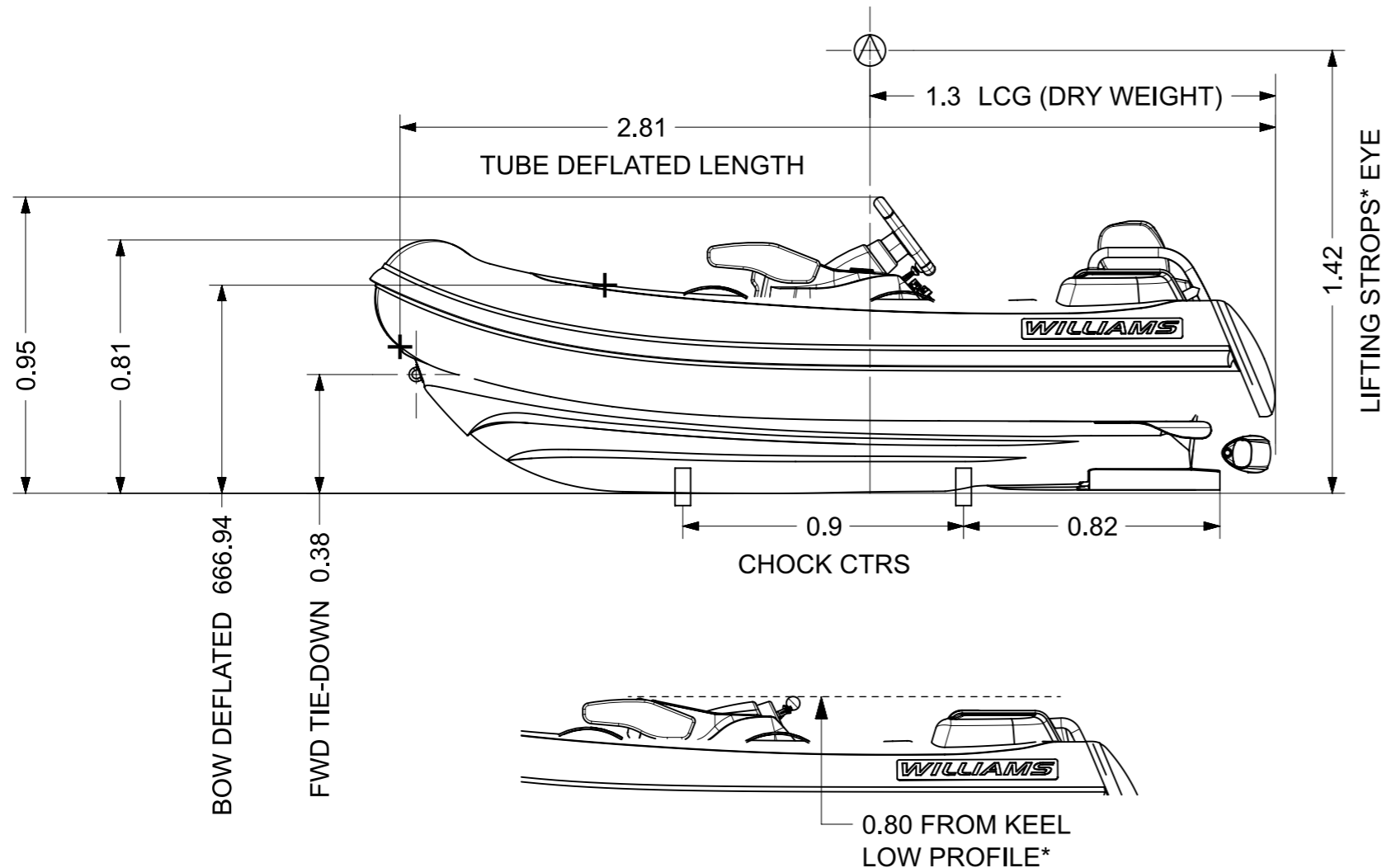
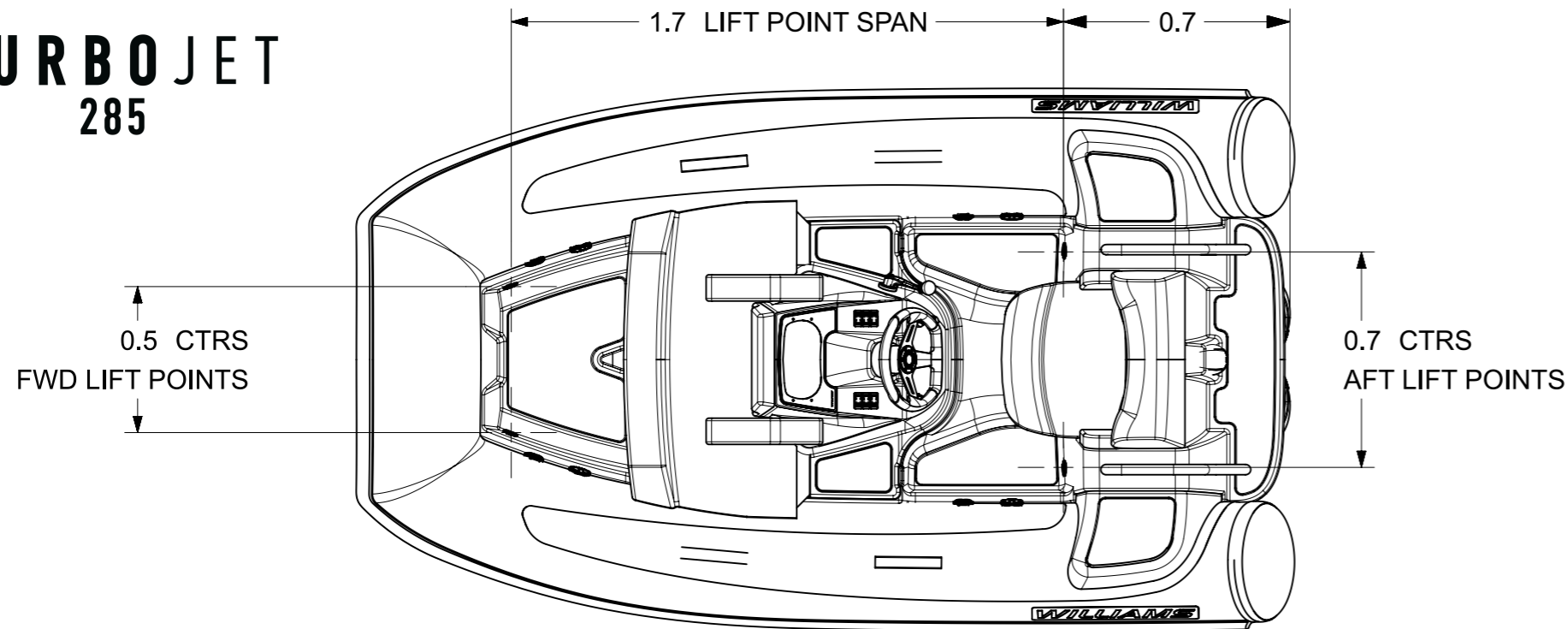

LENGTH O.A.	2.90m (±1%)
BEAM O.A.	1.70m (±1.5%)
DRAFT (FULLY LOADED)	0.23m / 0.35m
ENGINE	Rotax ACE 90 ECT
POWER	90hp ≅ 66.19kW
DRY WEIGHT	315Kg
SEATING CAPACITY	3 + 1 child
FUEL	PETROL
FUEL CAPACITY	40L
MAX. SPEED	46mph ≅ 74kph
No. TUBE COMPARTMENTS	4
CE DESIGN CATEGORY	C

1. LENGTH/ BEAM TOLERANCE DUE TO VARIATION IN TUBE AIR PRESSURE.
2. AVERAGE DRY WEIGHT STATED; ACTUAL WEIGHT DEPENDANT ON OPTIONS FITTED.
3. LOW PROFILE SPEC:
  - REMOVE STEERING WHEEL (QUICK RELEASE TYPE REQUIRED\*)
  - DEFLATE TUBES.
  - REMOVE BACKREST.
4. STANDARD CHOCKS\*: 99-0153  
CHOCK PROFILES DRAWING: RD1013

\*OPTIONAL ACCESSORY

REV.	DATE	DETAILS	FZ DRAWN	OB APPV'D
1	12/10/2023	PRODUCTION RELEASE	FZ	OB

NOT FOR PUBLICATION - THIS DRAWING IS THE PROPERTY OF WILLIAMS JET TENDERS LTD. AND IS ISSUED ON CONDITION THAT IT IS NOT COPIED, RE-PRINTED OR DISCLOSED EITHER WHOLLY OR IN PART TO ANY THIRD PARTY NOT AUTHORISED TO RECEIVE IT

NAME	DATE
FZ	12/10/2023
APPV'D	OB
PROJECT:	-
INSPECTION LEVEL:	-
MATERIAL & FINISH	-
REMOVE ALL BURRS & BREAK SHARP EDGES	GENERAL SURFACE FINISH Ra 1.6UM
GENERAL SURFACE FINISH Ra 1.6UM	DIMENSIONS IN MM UNLESS STATED
DO NOT SCALE DRAWING	

**WILLIAMS**

TURBOJET 285 (2024MY)

SCALE 1:20

SHEET 1 OF 1

WPT-000285TJ2024MY-DATASHEET-dwg.1

A3